

# Oil Mist Eliminator for Rolls Royce Avon Gas Turbines

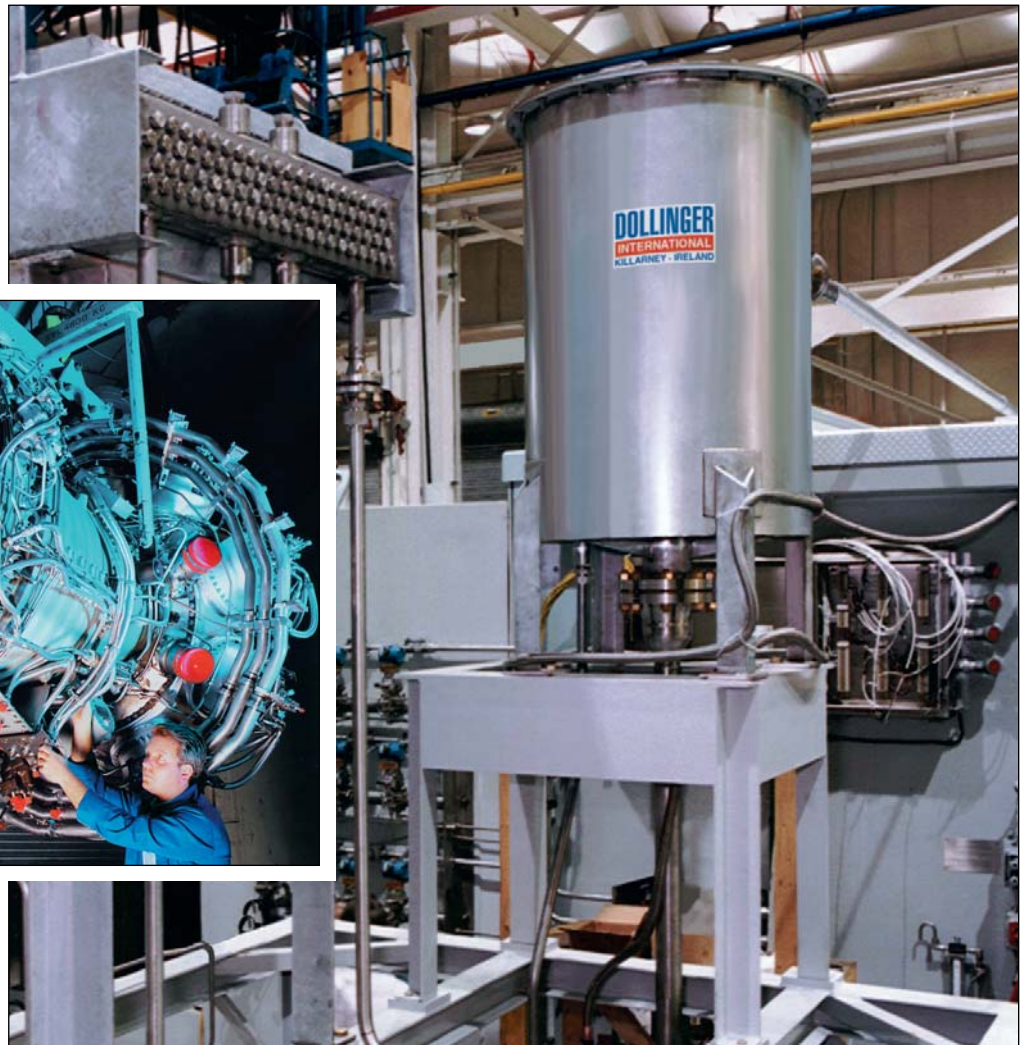
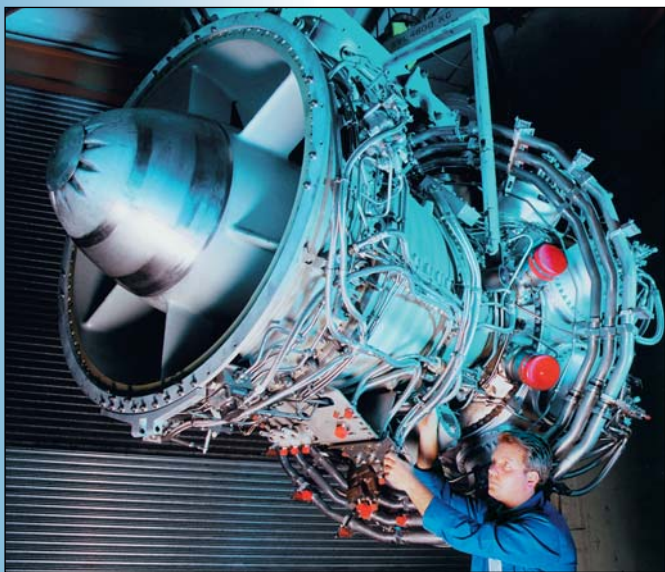

## Approved design

DOLLINGER is an approved supplier of Oil Mist Eliminators to Rolls-Royce plc.

The Dollinger OE-258R-300 has been designed for use with the Avon Industrial Gas Turbine.

## Features and benefits

- Recovery of expensive synthetic oil, resulting in reduced operating costs
- Prevents undue power loss and maintenance by

preventing oil mist from entering nearby air intake systems

- Complies with all current international environmental regulations

## No visible plume – guaranteed!

The Dollinger Oil Mist Eliminator (OME) range has been designed and engineered to completely eradicate all visible oil mist and plume.

After the straightforward installation, the Dollinger OME can operate up to 2 years maintenance-free, at 100% efficiency, resulting in improved

system performance, reduced oil consumption and maintenance.

No worries about compliance with current environmental regulations – the Dollinger OME meets or exceeds all known worldwide standards.

The Dollinger OME offers unequalled efficiency – 99.97% of all droplets and particles 0.3 micron and larger, and a guaranteed oil mist carryover of less than 5 ppm by weight.

Reliability and performance in a simple, compact design.



# Oil Mist Eliminator for Rolls Royce Avon Gas Turbines

## Design Features

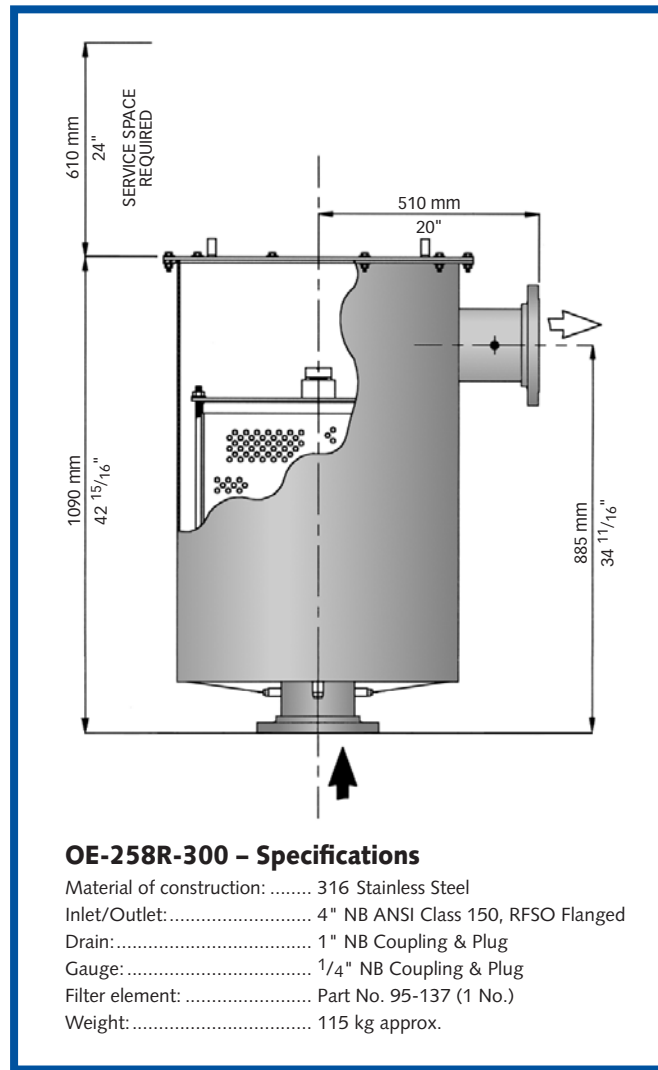

The rugged construction of the Dollinger OME makes it ideal for both on and offshore installation.

The following design features are included as standard:

- Grade 316 Stainless Steel construction
- Primary oil separator
- High-efficiency final-stage coalescing element
- ANSI Flange inlet/outlet connections

## Hundreds of installations – on and offshore



**Please contact:**

**DOLLINGER INTERNATIONAL**  
Ballycasheen, Killarney, County Kerry, Ireland  
Phone: +353-64-33322  
Fax: +353-64-33371  
Email: sales@dollinger.ie



**DOLLINGER**